



Gas & Flame Detection

3M™ Oldham™ OLCT 80

Fixed Gas Detection



- Detectors-Transmitters for Flammable, Toxic Gases and Oxygen
- Non-intrusive operation via intrinsically safe infrared remote control
- Remote versions available XP, IS
- Integrated relays
- Direct link, 4-20 mA, loop and isolated sensor mode



3M™ Oldham™ OLCT 80

Fixed Gas Detection

Unique advantages providing the solution you need

Design advantages

Pre-calibrated sensors for detection of:

- combustible gases: LEL catalytic and IR
- toxic gases
- oxygen

Series 80 detectors are compatible with all Industrial

Scientific sensors. Series 20, "Smart" Sensors are precalibrated.

Alarms

- 2 integrated gas alarms with relays
- 1 fault alarm with relay

Inputs

Series 80 sensors have up to 9 glands dedicated to cable wiring Design advantages:

The minimum configuration includes:

- 1 electrical input dedicated to a sensor.
- two 4-20 mA or binary inputs. This configuration allows any other sensor from the network to be recognized (e.g temperature sensor, emergency stop, flame detector, smoke detector).

Outputs

- 4/20 mA with smart signal processing
- analog signal 4-20 mA
- data signals between 0 and 4 - 20 and 25mA

The transmitted signal, between 0 and 3.2 mA and above 20 mA, can be processed to interpret and identify a wide range of trouble parameters such as: line faults, sensor faults, embedded electronics faults, ambiguity resolution, inhibition of calibration, maintenance call (initial drift or drift over time).

- RS485 (1200 bauds, 38kb Modbus ASCII for MX 62).

The RS485 link gives access to :

- sensor measurement
- status and default
- internal relay management

Relays

The relays are 2A / 250 VAC type with potential free SPDT contacts.

Two types of relays:

- 2 gas alarm relays or supplementary inputs
- 1 fault relay

The relays are actuated either

- directly by the sensor electronics or supplementary inputs, or
- from the MX62 central unit or the control system to which the sensor is connected.

The relays can be

- in safety mode or not,
- triggered on increasing or decreasing alarms,
- manually* or automatically acknowledged.

* By remote control, by pressing an external pushbutton connected to the dedicated binary input, by acknowledging on the MX 62 unit or the control system to which the sensor is connected.

Alarms

- 2 integrated gas alarms with relays
- 1 fault alarm with relay

Technical advantages

Stand-alone central unit

For relay control, the OLCT 80 can operate as a standalone unit: an indisputable advantage in a classified explosion risk zone.

Flexibility of connection modes

OLCT 80 sensors can be connected either:

- in loop (opto-isolated - up to 16 sensors),
- 4-20 mA,
- under direct power and operate as a central unit.

Operation traceability

The operator can check records locally for the most recent time-date stamped events.

Communication

Remote dialogue with the sensor using IR remote control.

Measurement power supply redundancy

Independent ports allow a redundant connection to the measurement unit.

Low power requirements

The leading edge technology used in the OLCT80 transmitter makes it very energy efficient.

This major advantage means that more sensors can be connected, with smaller wire cross-sections and over greater distances.

Logistic advantages

Loop arrangement

The transmitter is perfectly adapted to mounting and connection to the digital fieldbus loop of the MX 62 unit. Supporting 1 to 3 digital addresses:

- the sensor block (detection element),
- the two 4-20 mA auxiliary inputs.

Certification

The OLCT80 Series is certified to the specifications required by standards EN 50054, 45544 and 50104 (environmental standards, explosive and toxic gases and oxygen) and to the specifications of standards EN 50270, EN 6052 (electromagnetic compatibility, ingress protection).

OLCT 80 uses digital logic and software technologies.

The sensors are protected and in compliance with the specifications of standard EN 51271:

- analog and digital values track each other
- homogeneity of digital resolution and response time with the specifications required
- internal self-diagnostics

3M™ Oldham™ OLCT 80

Fixed Gas Detection

Type of Gases	Type of sensor	Range (ppm)	Operating temperature* (°C)	Relative humidity uncondensed	Pressure	Accuracy at full scale (at atmospheric pressure)	Life span (in months)	T (50)	IP	IS	AD
O ₂	electrochemical	30,00%	-20°C to +50°C	10% to 95% RH	Atm +/- 10%	from 5 to 30% = 0,4%vol	28	6	66	YES	YES
CO	electrochemical	100 300 1000	-20°C to +50°C	10% to 95% RH	Atm +/- 10%	+/- 2 ppm (range 0-100)	40	10	66	YES	YES
H ₂ S	electrochemical	30 100 1000	10% to 95% RH	10% to 95% RH	Atm +/- 10%	+/- 1,5 ppm (between 0-30 ppm)	36	15	66	YES	YES
NO	electrochemical	100 300 1000	-20°C to +50°C	10% to 95% RH	Atm +/- 10%	+/- 2 ppm (range 0-100)	36	15	66	YES	YES
NO ₂	electrochemical	10 30,0	-20°C to +50°C	10% to 95% RH	Atm +/- 10%	+/- 0,8 ppm	24	20	66	YES	NO
	electrochemical	10,0 30,0 100	100 -10°C to +50°C	10% to 95% RH	Atm +/- 10%	+/- 0,7 ppm range 0-10	36	15	66	YES	NO
Cl ₂	electrochemical	10,0	-20°C to +50°C	10% to 95% RH	Atm +/- 10%	+/- 0,5 ppm	24	50	66	YES	NO
H ₂	electrochemical	2000	-20°C to +50°C	10% to 95% RH	Atm +/- 10%	+/-5 ppm range 0-100	24	50	66	YES	YES
HCl	electrochemical	30,0 100	-20°C to +40°C	10% to 95% RH	Atm +/- 10%	+/- 0,5 ppm range 0-10	24	50	66	YES	NO
HCN	electrochemical	1,0 30,0	-20°C to +40°C	10% to 95% RH	Atm +/- 10%	+/- 0,3 ppm range 0-10	18	40	66	YES	NO
NH ₃	electrochemical	100 1000	-20°C to +40°C	10% to 95% RH	Atm +/- 10%	+/- 5 ppm	24	50	66	YES	YES
			-20°C to +40°C	10% to 95% RH	Atm +/- 10%	+/- 10 ppm range 0-1000					
O ₃	electrochemical	1,00	-10°C to +40°C	10% to 95% RH	Atm +/- 10%	+/-0,05 ppm	20	50	66	YES	NO
PH ₃	electrochemical	1,00	-20°C to +40°C	10% to 95% RH	Atm +/- 10%	+/- 0,05 ppm	18	40	66	YES	NO
ClO ₂	electrochemical	3,00	-20°C to +50°C	10% to 95% RH	Atm +/- 10%	+/- 0,3 ppm	24	50	66	YES	NO
SiH ₄	electrochemical	50	-20°C to +40°C	10% to 95% RH	Atm +/- 10%	+/- 1 ppm	18	40	66	YES	NO
AsH ₃	electrochemical	1,00	-10°C to +40°C	20% to 95% RH	Atm +/- 10%	+/- 0,05 ppm	18	40	66	YES	NO
CH ₄	catharometre	0-100%vol	-20°C to +50°C	10% to 95% RH	Atm +/- 10%	1% vol	60	5	66		
H ₂	catharometre	0-100%vol	-20°C to +50°C	10% to 95% RH	Atm +/- 10%	1% vol	60	5	66	YES	YES
NH ₃	catalytic	0-5000	-20°C to +50°C	10% to 95% RH	Atm +/- 10%	100 ppm	36	8	66	YES	YES
Flammable gas	catalytic	0-100% LIE	-20°C to +70°C	10% to 95% RH	Atm +/- 10%	1% LIE between 0- 60%LIE	60	5	66		
VOC	semi-conductor	500 ppm	-20°C to +50°C	10% to 95% RH	Atm +/- 10%	+/- 4 ppm if measure < 200 ppm	36	25	66	NO	YES
CO/H ₂ null	electrochemical	1000 ppm	-20°C to +50°C	10% to 95% RH	Atm +/- 10%	+/- 4 ppm if measure < 200 ppm	36	25	66	YES	YES
CO sensor						+/-20 ppm if measure>200 ppm				YES	YES

* Temperature at 20°C and at Atmospheric Pressure

Configuration Options

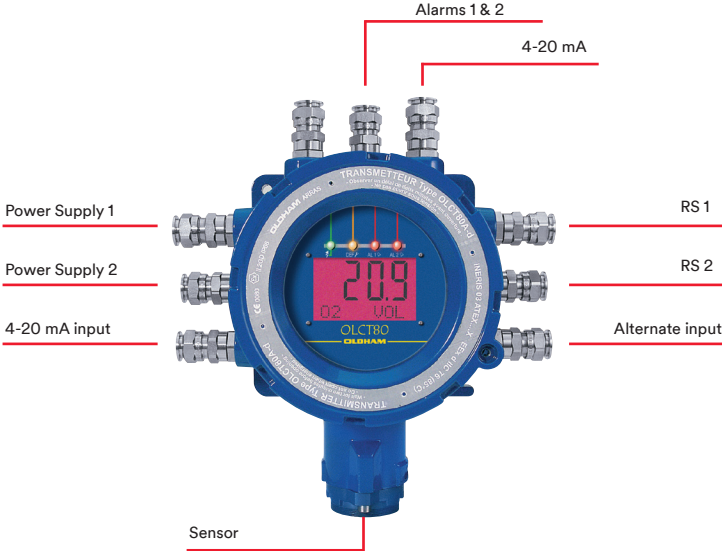

Standard Version

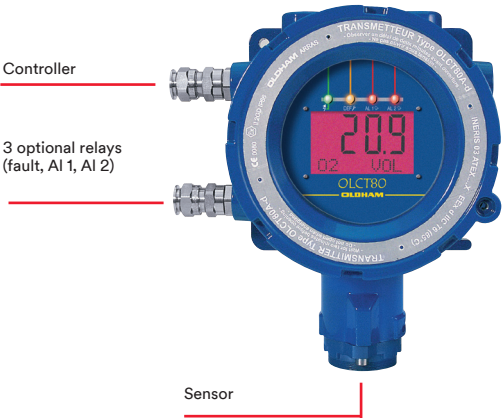

Stand Alone Version

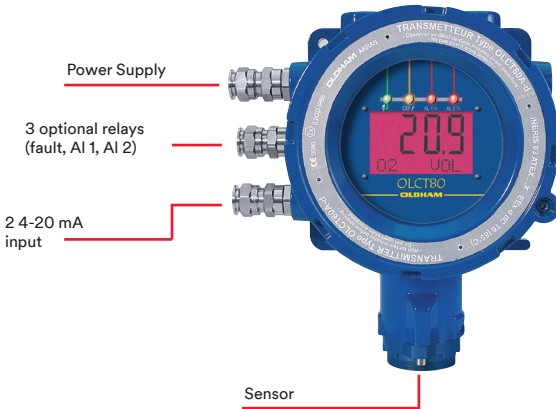

Digital Version

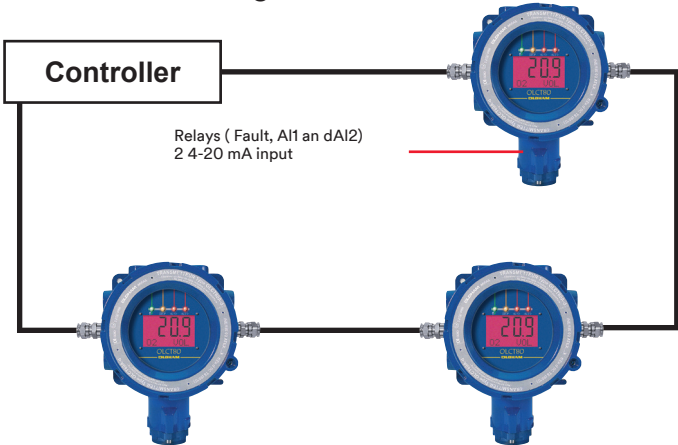

3M™ Oldham™ OLCT 80

Fixed Gas Detection

Specifications

Type	Transmitter-sensor
Detected gases	Explosive, toxic and oxygen
Detection principles	Catalytic, Electrochemical, IR, Semiconductor
Sensor block	Pre-calibrated
Device	Aluminium enclosure and stainless steel 316L for sensor housing
Visualisation	4-digit LCD display for measurement and one alphanumeric line for texts, Pictograms - backlighting 4 indicator lamps : one green : "Operation OK", one yellow : "Fault", red : "Alarm 1" and "Alarm 2"
Power supply	From 16 to 28 VDC at transmitter entry
Maximum power	with digital link - 0.2 W (electrochemical cell) - 1.3 W (catalytic / SM) with I output at 25 mA - 0.9 W (electrochemical cell) - 2 W (catalytic / SM) with I output at 25 mA and relays activated - 2.4 W (electrochemical cell) - 3.5 W (catalytic / SM)
Power supply to sensor terminals	Two independent inputs : 16 to 28 VDC (catalytic / IR / SM cells) 12 to 28 VDC (electrochemical cell)
Inputs	Two analog inputs 4-20 mA (load resistance 120 Ω, can be used as binary)

Signal outputs

Logic (relay contacts):	Relay
Analog:	Standardised 4-20 mA output
Digital:	Two independent opto-isolated RS 485 ports
Signal faults:	I < 0.5 mA
Alarms	2 programmable thresholds per channel

Relays

Type	SPDT
Number	3
Contact	RCT changer-over
Breaking capacity	2A / 250 VAC / 30 VDC
Wiring / connection:	Basic version, 6 inputs : 4 M20 and 2 M25 On request : 3 additional, 2 M20 and 1 M25
Load resistance on the 4-20 mA	500 Ω
Loop resistance	Under central unit 21 VDC: 128 ohms (electrochemical cell) - 32 Ω (catalytic / SM) - 16 Ω (IR)
Protection number	IP 66
Operating temperatures	- 20 °C to + 60 °C (electronics, see table for detection cells)
Dimensions	See drawings
Weight	OLCT 80 : 3,5 kg OLCT80 version IR : 5,3 kg

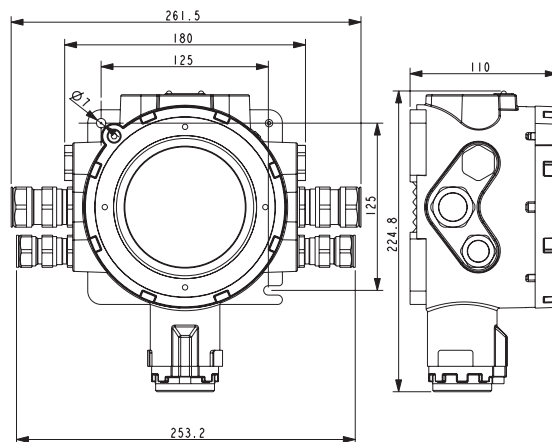

Accessories

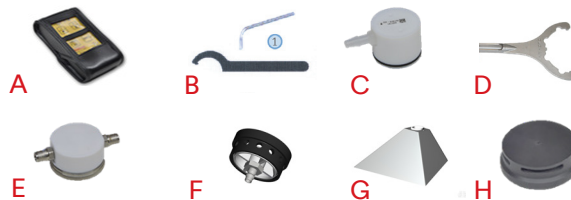

- A Infrared remote control
- B Tool kit
- C Bypass adapter
- D Cover key
- E Calibration cup
- F Remote gas introduction device
- G Gas collector
- H Splash guard

Homologations

Certification Atex	
OLCT 80 d ATEX II 2GD Ex d IIC T6...T5 Gb Ex tb IIIC T85°C...T100°C Db INERIS 03ATEX0240X	OLCT 80 id ATEX II 2GD Ex d ia IIC T4 Gb Ex tb ia IIIC T135°C Db INERIS 03ATEX0240X
Chine	
OLCT 80 d GYJ17.1201X - Ex d IIC T6/T5 Gb	OLCT 80 id GYJ17.1202X - Ex d ia IIC T4 Gb
Electromagnetic compatibility	
Complies with EN 50270	

As an ISO 9001 & ISO 14001 approved company, OLDHAM quality assurance programmes demand the continuous assessment and improvement of all OLDHAM products. Information in this leaflet could thus change without notification and does not constitute a product specification. Please contact OLDHAM or their representative if you require more details.

AMERICAS - Texas (USA)
4055 Technology Forest Blvd.
The Woodlands, TX 77381
Tel.: +1-800-247-7257
Fax: +1-281-292-2860

EMEA
ZI Est, Rue Orfila,
CS 20417
62027 ARRAS CEDEX, France
Tel.: +33-3-21-60-80-80
Fax: +33-3-21-60-80-00

ASIA PACIFIC
290 Guiqiao Road
Pudong, Shanghai 201206
People's Republic of China
Tel.: +86-21-3127-6373
Fax: +86-21-3127-6365



Copyright © 2018 3M, 3M Gas & Flame
Detection. All rights reserved.
gasdetection.3m.com. GF-30027E-EN