

Explosion proof PTZ camera station



Key Features

- Max. 2M (1920 x 1080) resolution
- 4.44 ~ 142.6mm (32x) optical zoom, 16x digital zoom
- H.264, MJPEG dual codec, Multiple streaming
- Day & Night (ICR), WDR (120dB)
- Intelligent video analytics
- sLCus C1/Z1/cLCus C1/D1/INMETRO / cLC CSA certified
- Electro-polished 316L stainless steel on all welded assemblies
- Camera station window in toughened glass
- Integrated Wiper, Optional Fiber (TNP-6320E2WF, TNP-6320E1WF)
- Supply voltage (24 VAC or 110VAC) depend on the model

Dimensions

Unit: mm

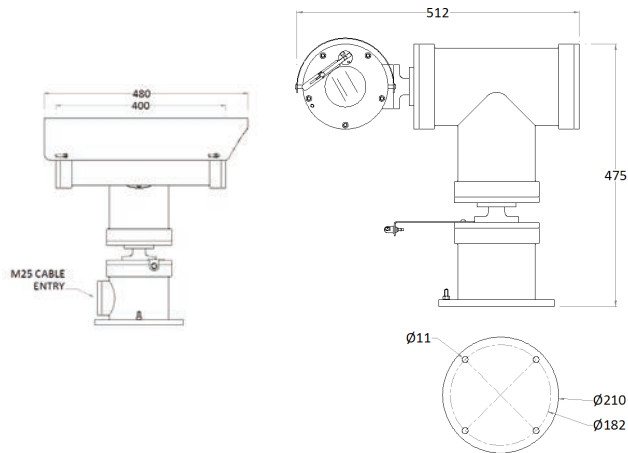

Accessories (Optional)



HT-E-BPW6800



HTE-E-XWP10UL

TNP-6320E*

VIDEO	
Image sensor	1/2.8" 2.38M CMOS
Resolution	Resolution: 1920x1080 @60fps to 320x180.
Lens	32x optical 16x digital zoom 4.44-142.6 mm F1.6 to F4.4, horizontal angle of view 62.8° - 2.23°
Pan / Tilt Range	360° Endless / 180°
Pan / Tilt Speed	45° per second / 24° per second
Min. Illumination	Color : 0.3Lux (1/30sec, F1.6, 50IRE), B/W : 0.03Lux (1/30sec, F1.6, 50IRE)
Streaming	H.264, MJPEG dual codec, multiple streaming, VBR/CBR
Features	Intelligent video analytics, motion detection, day & night (ICR), WDR (120dB), auto focus, auto Iris, AGC, SSSDR, ATW, SSNRIII, BLC, DIS, Defog
Standards protocols	ONVIF Profile S, TCP/IP, UDP/IP, RTP(UDP), RTP(TCP), RTCP, RTSP, NTP, HTTP, HTTPS, SSL, DHCP, FTP, SMTP, ICMP, IGMP, SNMPv1/v2c/v3(MIB-2), ARP, DNS, DDNS, QoS, PIM-SM, UPnP, Bonjour

SPECIFICATIONS

Sun shield	Standard stainless steel 316L mirror finish
Integral wiper	silicone wiper blades that are resistant and do not perish after long exposure to ozone, UV, ice, snow, heat or cold)
Integral Fiber (Optional)	Built-in Fiber Module (Simplex single-mode 9/125µm)(WF Models only)
Ingress protection rating	IP66/67
Temperature rating	-40°C ~ +60°C (-40°F ~ +140°F)

ELECTRICAL

Supply voltage options	24 VAC OR 110 (depends on the model number)
Power Consumption	80W Maximum
Cable entry	Three M20 entries located in housing rear flange
Body material	Electro-polished 316L stainless steel on all welded assemblies
Fixings material	A4 stainless steel
Camera station window	Toughened glass

CERTIFICATIONS

INMETRO	Ex d IIC T4 (T5 On Request) Gb -60° C ≤ Ta ≤ +60° C Ex tb IIIC T135° C Db IP66/67. Certificate Number: TUV 12.1080X / TUV 12.1081X
LCus C1/Z1	Class 1 Zone 1 A Ex d IIC T4 (T5 On Request) LC13A11396 Gb -60° C ≤ Ta ≤ +60° C. UL 60079-0:2009 & 60079-1:2009. Certificate Number: 11396-1S-UL
cLCus C1/D1	Class I, Division 1, Groups B,C,D, -60°C ≤ Ta ≤ 60°C T4/ Class II, Division 1, Groups E, F, G IP67 CSA-C22.2 No:30-M1986 No:25-1966(R2009) CSA-C22.2 No:60065-03(R2012) & UL1203,UL60065(ED.7). Certificate Number: 11671-1S / 11677-1S
cLC CSA	Ex d IIC T4 (T5 On Request) LC1311396 -60°C ≤ Ta ≤ +60°C. CAN CSA-C22.2 No.60079-0:2011 & 60079-1-2011. Certificate Number: 11396-1S-CSA
Weight	Up to 53 Kg (117lb)

Model Number:

TNP-6320E□□-□ :

110 VAC : 2
24 VAC : 1

Z : cLCus C1/D1
U : LCus C1/Z1
M : INMETRO
C : cLC CSA

Fiber/Wiper : WF
Wiper : W